

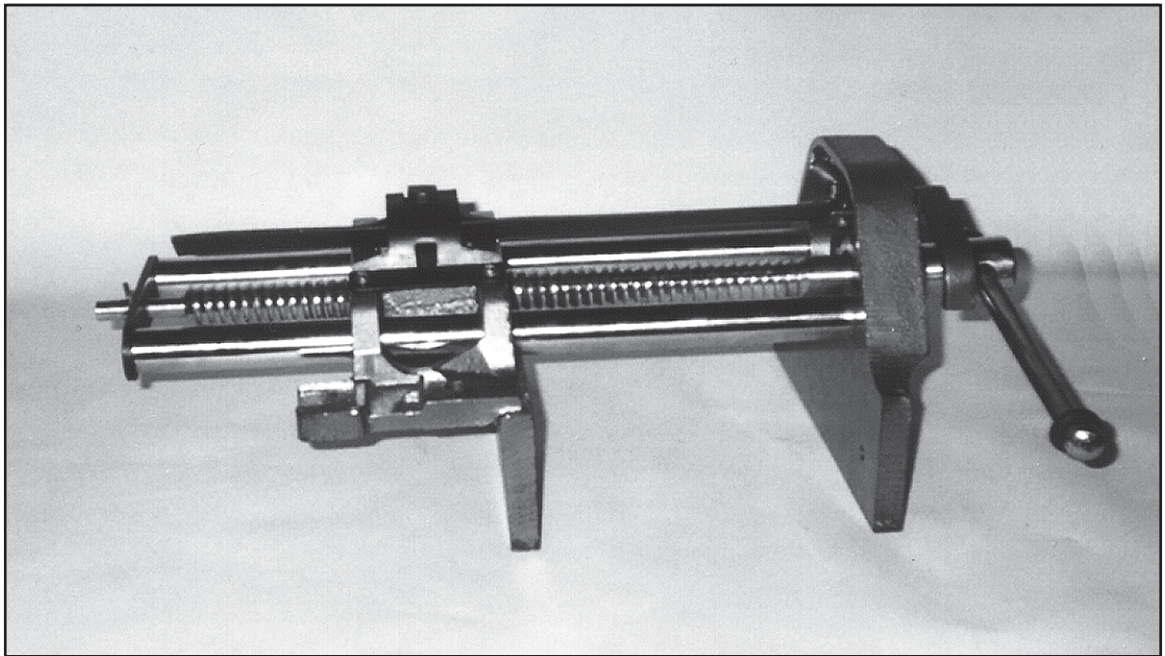

# 9" QUICK RELEASE WOODWORKING VISE

**Model 94386**

## OPERATING INSTRUCTIONS



Due to continuing improvements, actual product may differ slightly from the product described herein.



3491 Mission Oaks Blvd., Camarillo, CA 93011

Visit our Web site at <http://www.harborfreight.com>

Copyright© 2006 by Harbor Freight Tools®. All rights reserved. No portion of this manual or any artwork contained herein may be reproduced in any shape or form without the express written consent of Harbor Freight Tools.

**For technical questions or replacement parts, please call 1-800-444-3353**

## SPECIFICATIONS

Jaw Width	9 Inches
Throat Depth	3 Inches
Maximum Jaw Opening	10-5/16 Inches
Jaw Hardness	25-30 HRC
Rear Mounting Hole Dimensions	.435" Diameter x 2 and .420"W x .714"H x 2
Overall Dimension	6.0"L X 9.0"W X 18.0"H
Net Weight	24 Lbs.

## SAVE THIS MANUAL

**You will need the manual for the safety warnings and precautions, operating and maintenance procedures, parts list and diagram. Keep your invoice with this manual. Write the invoice number on the inside of the front cover. Keep the manual and invoice in a safe and dry place for future reference.**

## SAFETY WARNINGS AND PRECAUTIONS

1. **KEEP PRODUCT USAGE AREA CLEAN.** Cluttered areas invite injuries.
2. **KEEP CHILDREN AWAY FROM PRODUCT USAGE AREA.** Do not allow children to handle this product.
3. **DO NOT USE THIS PRODUCT IF UNDER THE INFLUENCE OF ALCOHOL OR DRUGS.** Read warning labels on prescriptions to determine if your judgement or reflexes are impaired while taking drugs. If there is any doubt, do not use this product.
4. **USE EYE PROTECTION.** Wear ANSI approved safety impact goggles. Goggles are available from Harbor Freight Tools.
5. **DRESS SAFELY.** Do not wear loose clothing or jewelry as they can become caught in moving parts. Wear a protective hair covering to prevent long hair from becoming caught in the moving parts.
6. **DO NOT OVERREACH.** Keep proper footing and balance at all times.
7. **STAY ALERT.** Watch what you are doing at all times. Use common sense. Do not operate this product when you are tired or distracted from the job at hand.

8. **CHECK FOR DAMAGED PARTS.** Before using this product, carefully check that it will operate properly and perform its intended function. Check for damaged parts and any other conditions that may affect its operation. Replace or repair damaged or worn parts immediately.
9. **MAINTAIN PRODUCT WITH CARE.** Keep this product clean and dry, and moving parts lightly lubricated for better performance. Keep the Handle dry, clean and free from oil, grease, and solvents.
10. **USE THE RIGHT PRODUCT FOR THE RIGHT JOB.** Do not attempt to force a small tool or attachment to do the work of a larger industrial tool. There are certain applications for which this tool was designed. It will do the job better and more safely at the rate for which it was intended. Do not modify this tool and do not use this tool for any purpose other than which it was intended.

## UNPACKING

When unpacking, check to make sure all parts shown on the Parts List (page 5) are included. If any parts are missing or broken, please call Harbor Freight Tools at the number shown on the cover of this manual as soon as possible.

**NOTE: Always mount the vise to a level workbench that is capable of supporting the weight of the vise and all work-pieces.**

**NOTE: All parts below refer to the parts listed on page 5 of this manual.**

### Setting Up The Vise:

1. Use the mounting holes on the Vise Plate (1) as a template. Lift the Vise against the workbench and, with a pencil, mark the points at which to fasten the Vise to the workbench. Set the Vise aside. **See Figure 1 next page.**
2. Drill the holes of the appropriate size (where previously marked with a pencil) into the workbench. **Caution:** Before drilling holes, always check to make sure that no hidden electrical wires or cords are in the drilling path.
3. Carefully set the Vise into place against the workbench with the mounting holes corresponding to the holes previously drilled through the top of the workbench.
4. Insert hardened steel bolts (not provided), of the appropriate diameter through the Vise Plate (1) and into the workbench. The length mounting bolts will vary, depending on the thickness of workbench the Vise it is to be attached to.

- From the underside of the workbench, put the appropriate size washers, lock washers and nuts on the bolts (not provided). Tighten all the nuts, securing the Vise Plate (1) to the workbench. Be sure the Vise is securely attached to the workbench before working with the Vise.

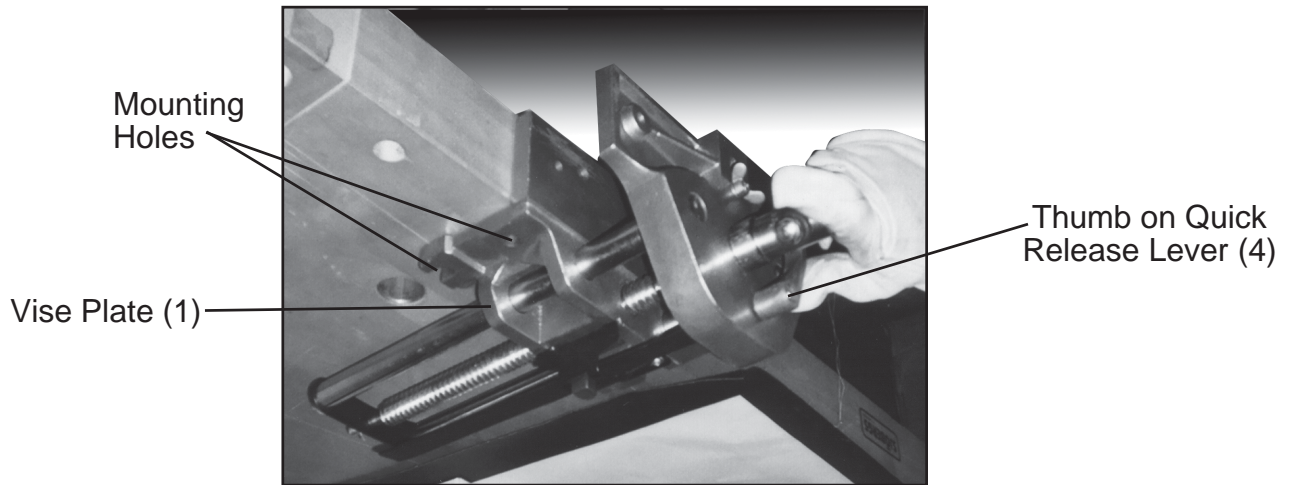
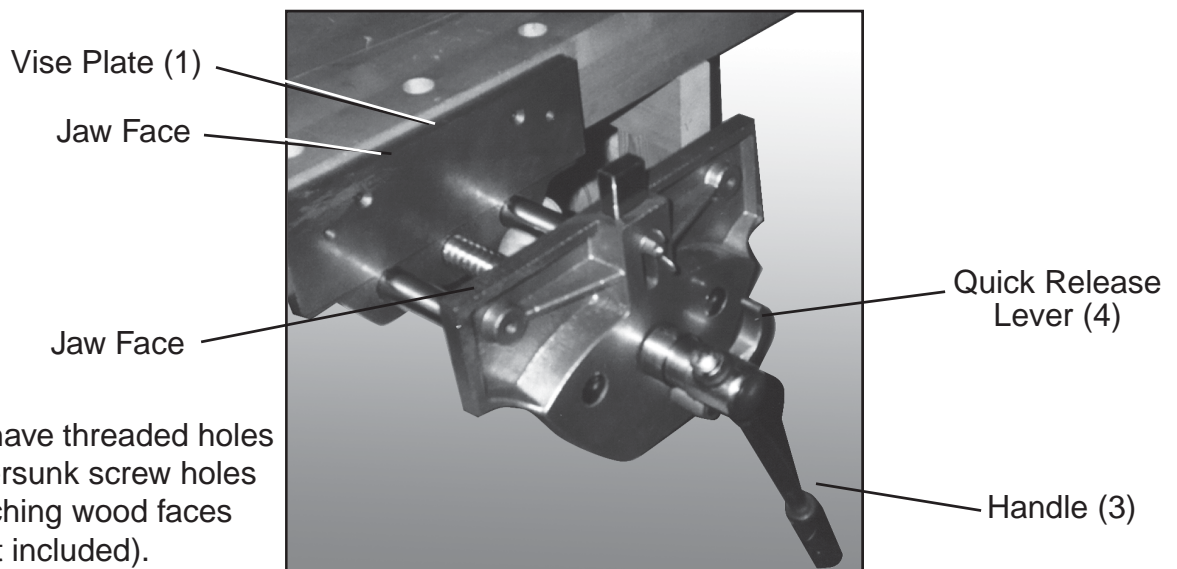

**Figure 1**

## OPERATING INSTRUCTIONS

Note: By pushing down on the Quick Release Lever (4), you can release the Jaws so the Jaws can be easily and quickly slid open or closed.

- Slide the Jaws (2) open by either turning the Handle (3) or using the Quick Release Lever. Place the workpiece you are working on inside the Jaws. Tighten the Jaws (2) against the workpiece by turning the Handle (3) clockwise until your workpiece is held securely. **Caution:** Damage could occur if you over-tighten the Handle (3). Avoid marring the workpiece surface. **See Figure 2.**
- To remove the object you are working on, turn the Handle (3) counterclockwise two to three times, opening the Jaws (2). Remove your workpiece.



**Note:** Jaws have threaded holes and countersunk screw holes for attaching wood faces (not included).

**Figure 2**



## PARTS LIST

PART #	DESCRIPTION	QTY
1	Vise Plate	1
2	Jaws	2
3	Handle	1
4	Quick Release Lever	1
5	Lead Screw	1

Note: No replacement parts are available for this product.

Part (4)

## PARTS DESCRIPTION

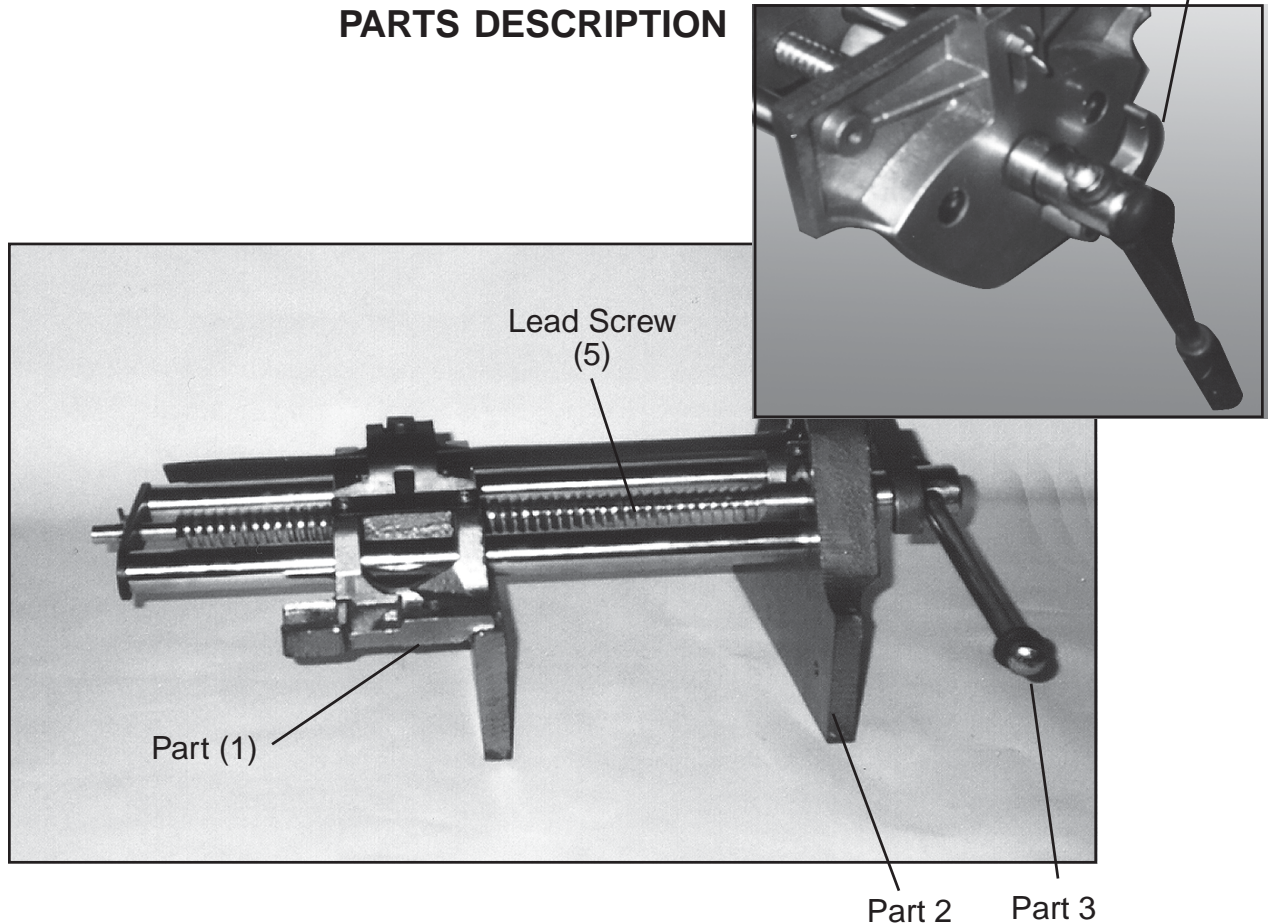

### PLEASE READ THE FOLLOWING CAREFULLY

THE MANUFACTURER AND/OR DISTRIBUTOR HAS PROVIDED THE PARTS DIAGRAM IN THIS MANUAL AS A REFERENCE TOOL ONLY. NEITHER THE MANUFACTURER NOR DISTRIBUTOR MAKES ANY REPRESENTATION OR WARRANTY OF ANY KIND TO THE BUYER THAT HE OR SHE IS QUALIFIED TO MAKE ANY REPAIRS TO THE PRODUCT OR THAT HE OR SHE IS QUALIFIED TO REPLACE ANY PARTS OF THE PRODUCT. IN FACT, THE MANUFACTURER AND/OR DISTRIBUTOR EXPRESSLY STATES THAT ALL REPAIRS AND PARTS REPLACEMENTS SHOULD BE UNDERTAKEN BY CERTIFIED AND LICENSED TECHNICIANS AND NOT BY THE BUYER. THE BUYER ASSUMES ALL RISK AND LIABILITY ARISING OUT OF HIS OR HER REPAIRS TO THE ORIGINAL PRODUCT OR REPLACEMENT PARTS THERETO, OR ARISING OUT OF HIS OR HER INSTALLATION OF REPLACEMENT PARTS THERETO.



**CENTRAL  
FORGE®**

**LIMITED 90 DAY  
WARRANTY**

Harbor Freight Tools Co. makes every effort to assure that its products meet high quality and durability standards, and warrants to the original purchaser that this product is free from defects in materials and workmanship for the period of 90 days from the date of purchase. This warranty does not apply to damage due directly or indirectly, to misuse, abuse, negligence or accidents, repairs or alterations outside our facilities, or to lack of maintenance. We shall in no event be liable for death, injuries to persons or property, or for incidental, contingent, special or consequential damages arising from the use of our product. Some states do not allow the exclusion or limitation of incidental or consequential damages, so the above limitation of exclusion may not apply to you. **THIS WARRANTY IS EXPRESSLY IN LIEU OF ALL OTHER WARRANTIES, EXPRESS OR IMPLIED, INCLUDING THE WARRANTIES OF MERCHANTABILITY AND FITNESS.**

To take advantage of this warranty, the product or part must be returned to us with transportation charges prepaid. Proof of purchase date and an explanation of the complaint must accompany the merchandise. If our inspection verifies the defect, we will either repair or replace the product at our election or we may elect to refund the purchase price if we cannot readily and quickly provide you with a replacement. We will return repaired products at our expense, but if we determine there is no defect, or that the defect resulted from causes not within the scope of our warranty, then you must bear the cost of returning the product.

This warranty gives you specific legal rights and you may also have other rights which vary from state to state.

**3491 Mission Oaks Blvd. • PO Box 6009 • Camarillo, CA 93011 • (800) 444-3353**